

# Journey of Rajkot Project

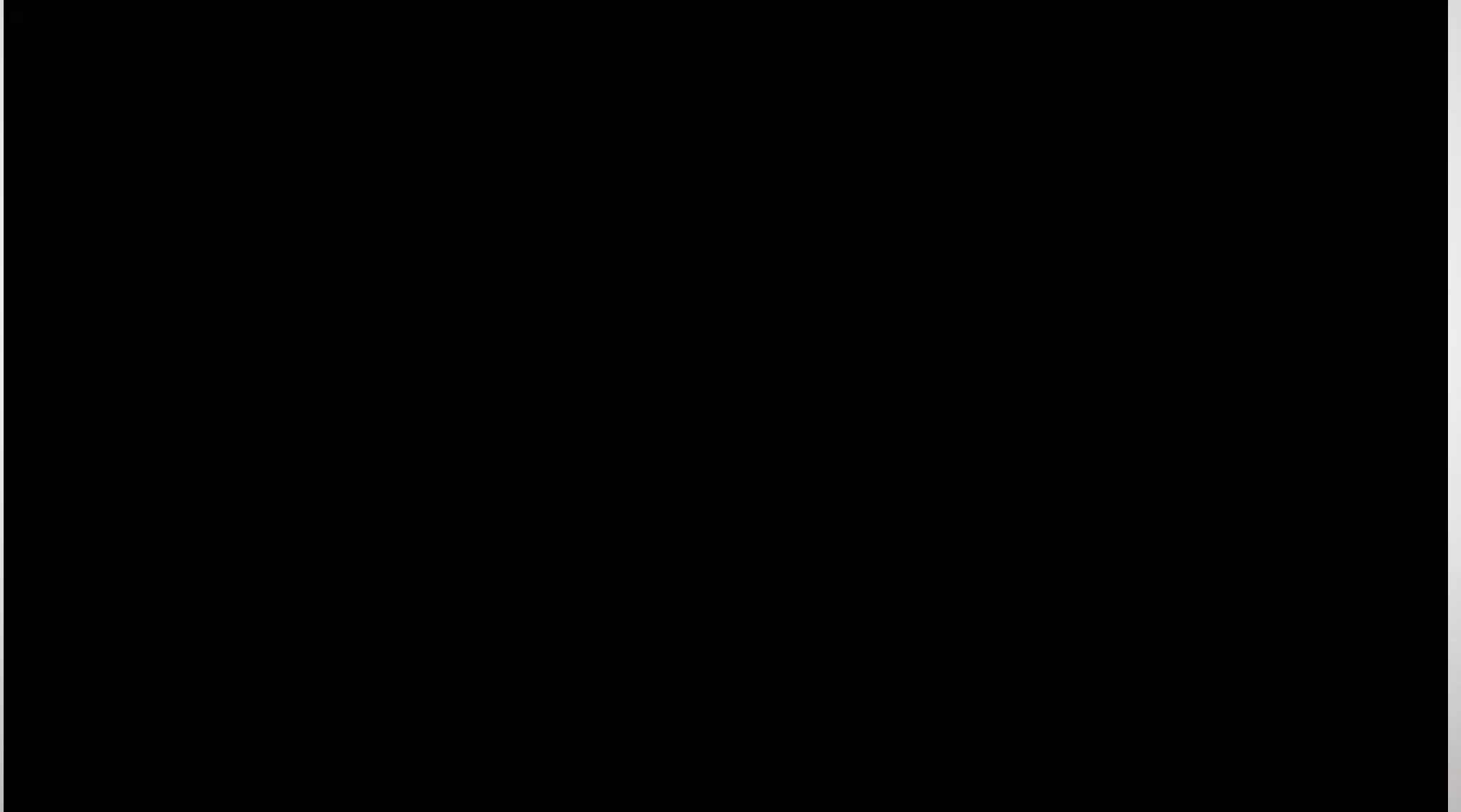

# Outinord Technology



# Light House Project Rajkot Review.

## LIGHT HOUSE PROJECT AT RAJKOT, GUJARAT



### Light House Project at Rajkot, Gujarat

Project Brief	
Location of Project	Raiya Smart City Area, TPS No-32, FP63/10
No. of DUs	1,144 (S+13)
Plot area	39,599sq.mt.
Carpet area of each DU	39.77 sq.mt.
Total built up area	62,369sq.mt.
Technology being used	Monolithic Concrete Construction using Tunnel Formwork





# Material despatched from Factory Chakan Pune.



## Arrival at Rajkot Site





# Assembly and Installation of Tunnel formwork at Rajkot Site.





# Tunnel formwork Working at Rajkot Site.





# Tunnel formwork Working at Rajkot Site.



# Tunnel working at Rajkot Site

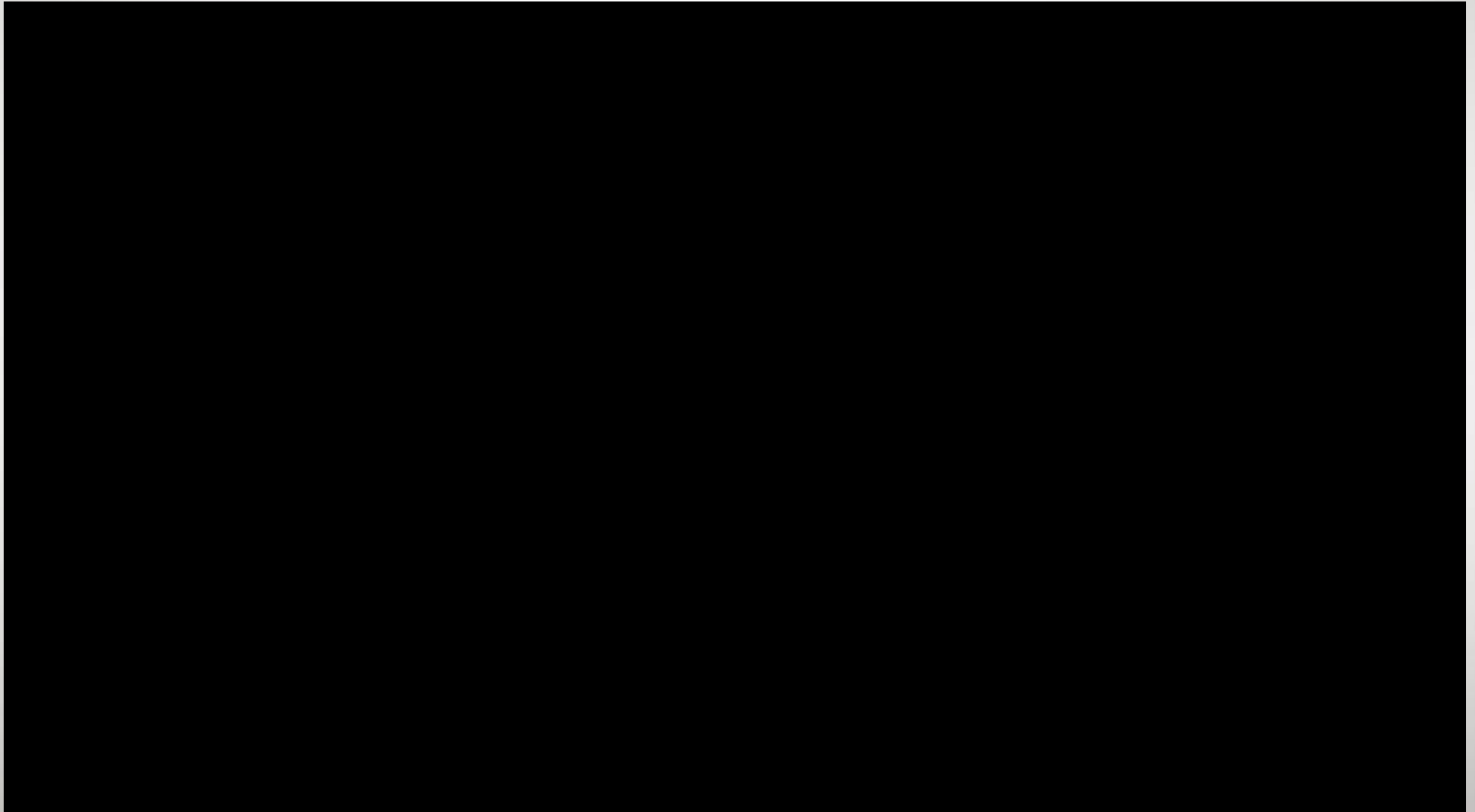



INDIA TV

www.indiatv.in

# मोदी की ड्रोन वाली मॉनिटरिंग



मैं जिग्रासु मेहता आपके  
समक्ष लाइट हाउस  
प्रोजेक्ट राजकोट की  
गतिविधि प्रस्तुत करना  
चाहता हूँ

इंडिया टीवी

SUN 19:59

TATA sky

India TV also available on Tata Sky- 514

# Media Limelight





# GHTC Light House Project







# Honourable Shri Modiji Handing over Keys to the Recipient

## DREAMS OF POOR !!

### INAUGURATION OF LIGHT HOUSE PROJECT - RAJKOT (GUJARAT)

ON

**19<sup>th</sup> OCT, 2022** by  
HON'BLE PRIME MINISTER  
**SHRI NARENDRA MODI**



**SHRI NARENDRA MODI**  
Hon'ble Prime Minister, India



**SHRI BHUPENDRA PATEL**  
Hon'ble Chief Minister, Gujarat



### Light House Project Will Benefit **1144** Poor Families With

- ☑ Spacious and Well-Ventilated 2 Bedrooms, Kitchen & Bathroom Facilities
- ☑ Three Lift Facilities in Each Towers
- ☑ Rapid Construction with Low Maintenance
- ☑ Durable, Comfortable & Affordable House
- ☑ Safe against Earthquake & Cyclone
- ☑ Easy approach to Public Transport, Health, Education & Other Facilities
- ☑ Healthy and Green Environment for Better Living Standard



Highest **BUILT-UP AREA (74207 SQ.M.)** among all Six Light House Project constructed under the Global Housing Technology Challenge - India With **MONOLITHIC CONCRETE CONSTRUCTION TECHNOLOGY** with using **TUNNEL FORM WORK** having 1144 Houses completed in **JUST 15 MONTHS**



**Malani Construction Co.**

Malani Complex, 58 - Kotecha Nagar, Kalawad Road, Rajkot | E-mail : [ho@malaniconstruction.com](mailto:ho@malaniconstruction.com)



# GHTC Rajkot Project Final handing over



clideo.com



# **Some other Outinord India Projects**

# Playtor Karegaon 2016

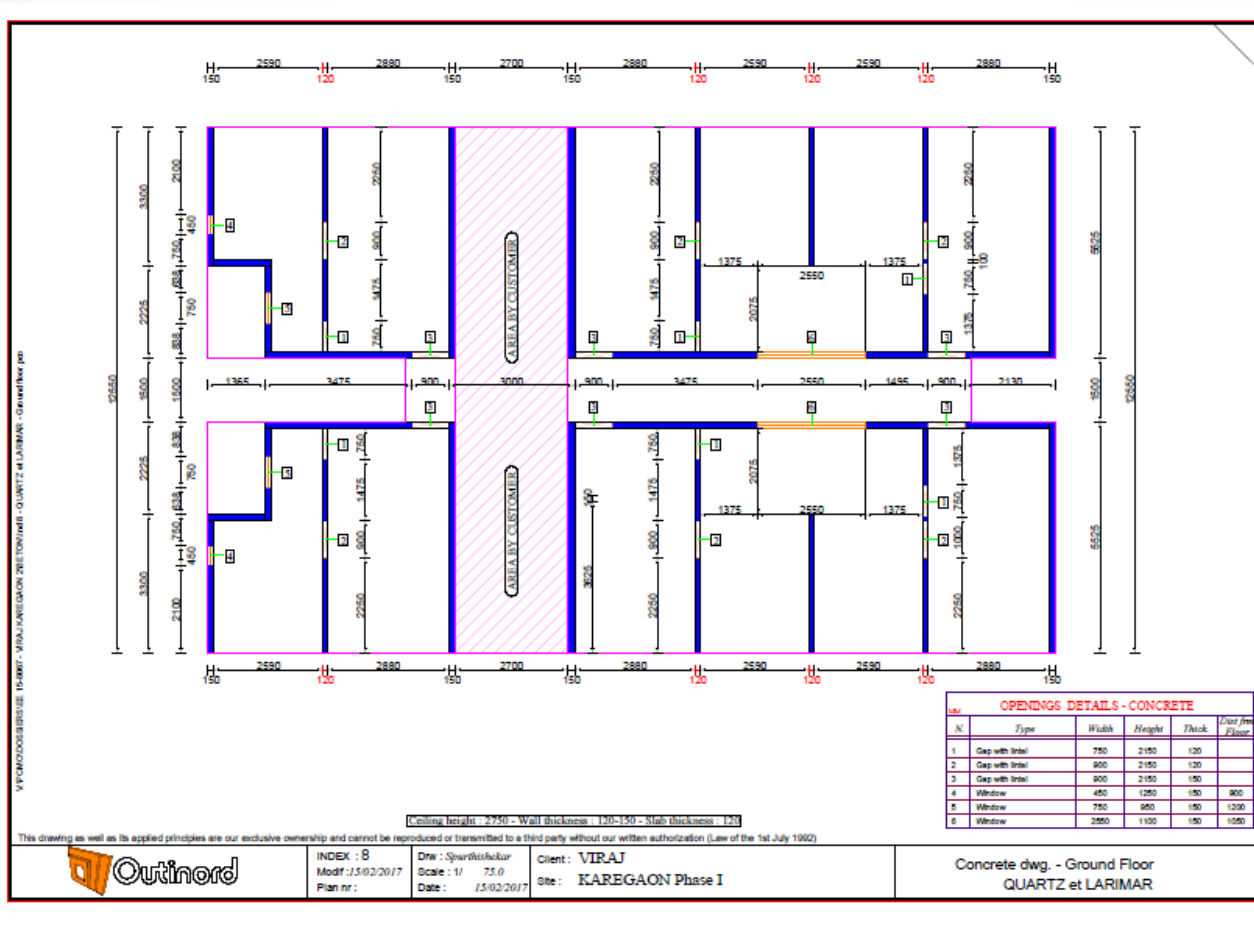



# Playtor Karegaon



Playtor lifespace Pvt Ltd., project in Karegaon, pune. They were been awarded for the “Best Project In EWS – Category in the State of Maharashtra from Shri Hardeep Singh Puri, Hon’ble Minister of State ( Independent charge ) Ministry of Housing and Urban Affairs, Govt. of India 2019



12 Apartment/floor  
G+4 Building

# Vtp Talegaon - 2019

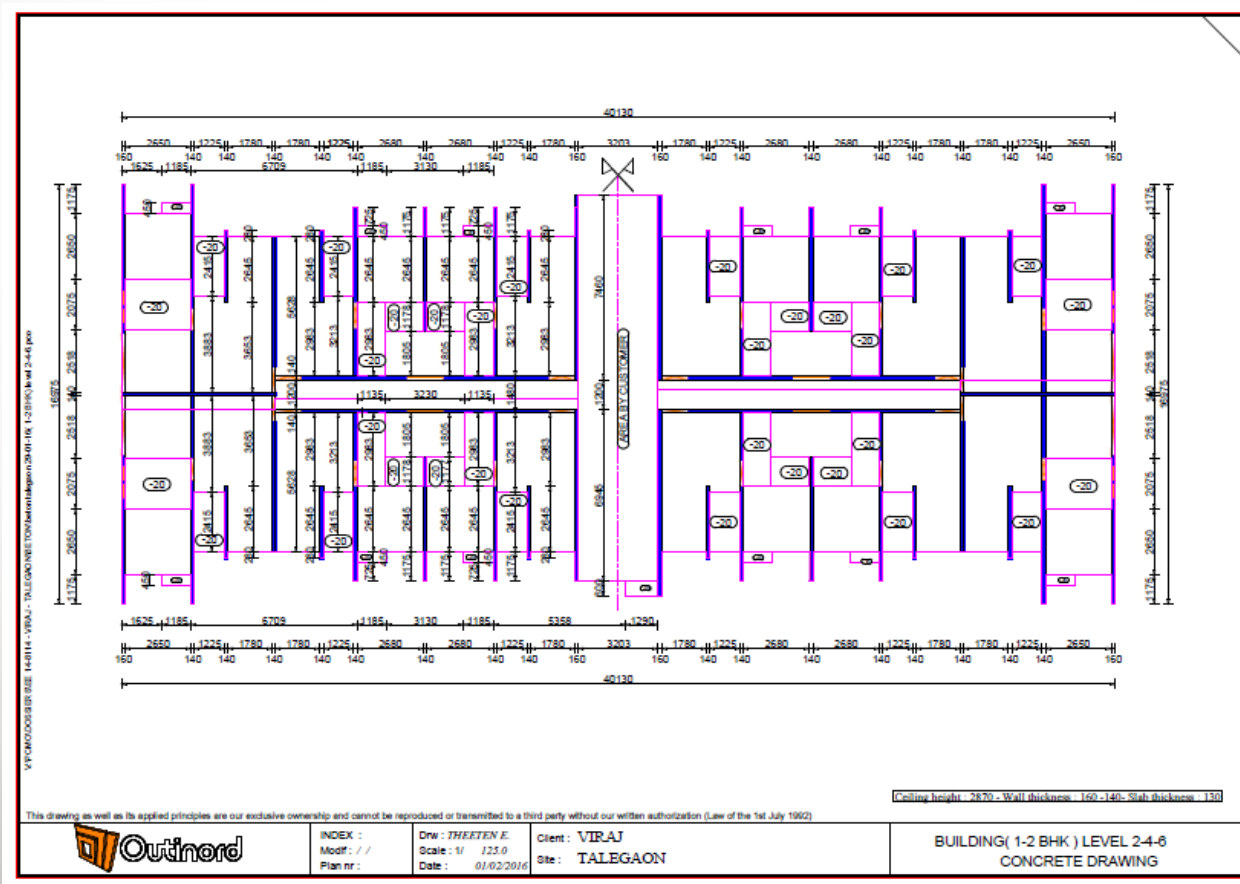



# Vtp talegaon



VTP, Project in Bhagyasthan Talegaon Pune in 2019  
G+7 Floor, 12 apartment/ floor

# Godrej Properties 2020

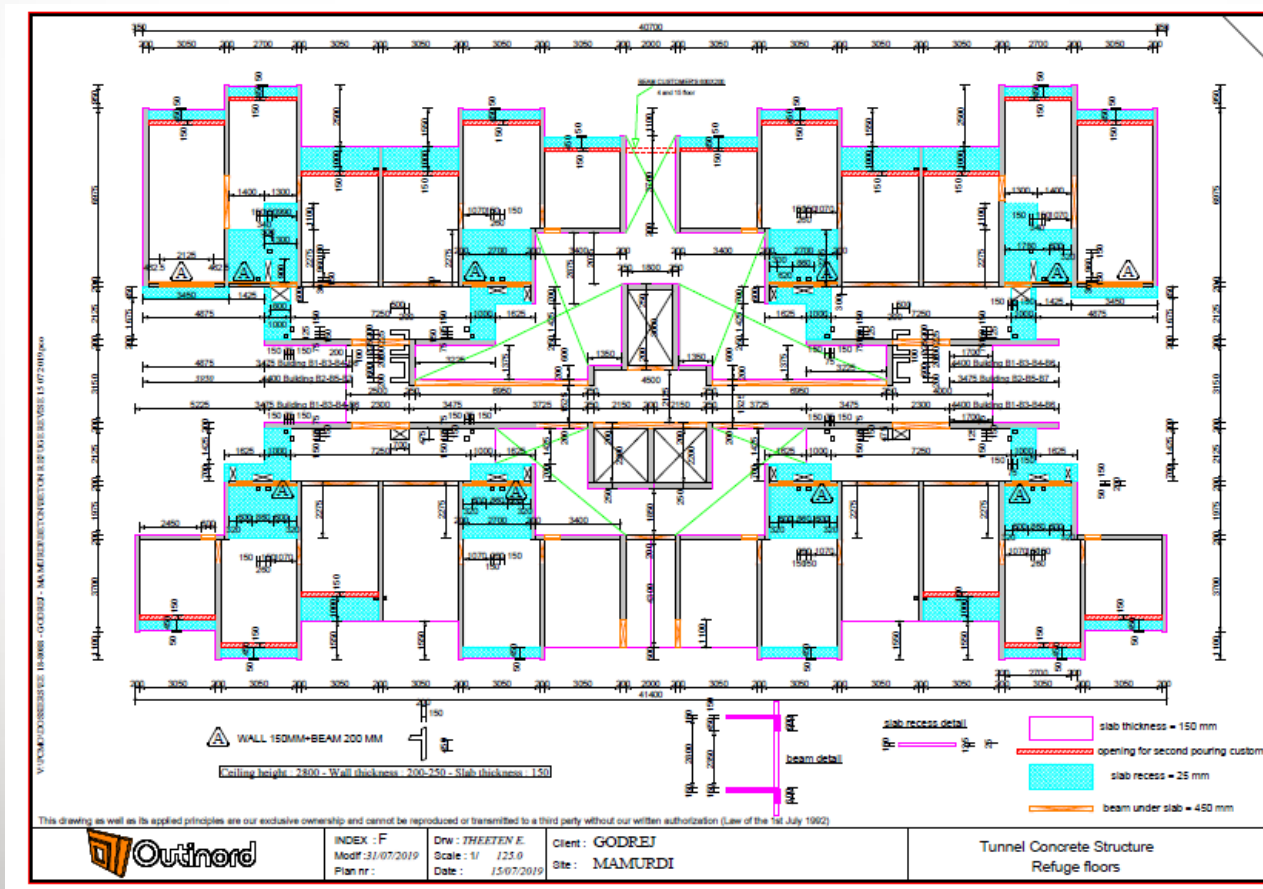



# Godrej Properties

Godrej Skyline Pvt Ltd  
for their project in  
Mamurdi, Pune  
Supplied 7 sets, for 7



# GHTC LIGHT HOUSE – RAJKOT 2021

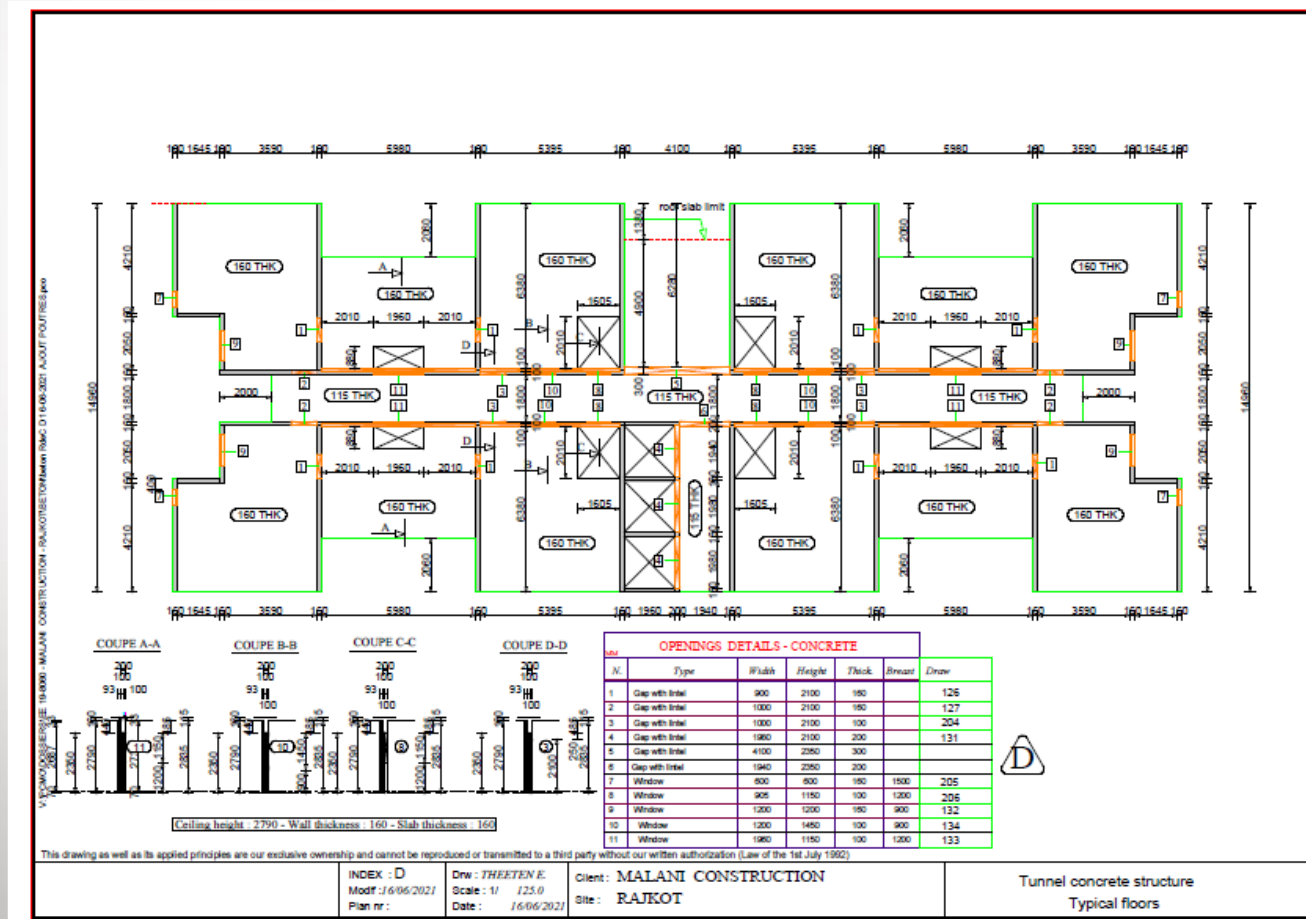

Government of India, Global Housing technology challenge India (GHTC India). 1144 apartments, 11 no's of blocks with S +13 floors.



# GHTC LIGHT HOUSE - RAJKOT



Inauguration by Honourable PM Shri Modiji



Presentation to PM for construction status by Jignasu Mehta

# GHTC LIGHT HOUSE - RAJKOT





# GHTC LIGHT HOUSE - RAJKOT



# GHTC LIGHT HOUSE - RAJKOT



# Vilas Javdekar – EWS Orizzonte 2021

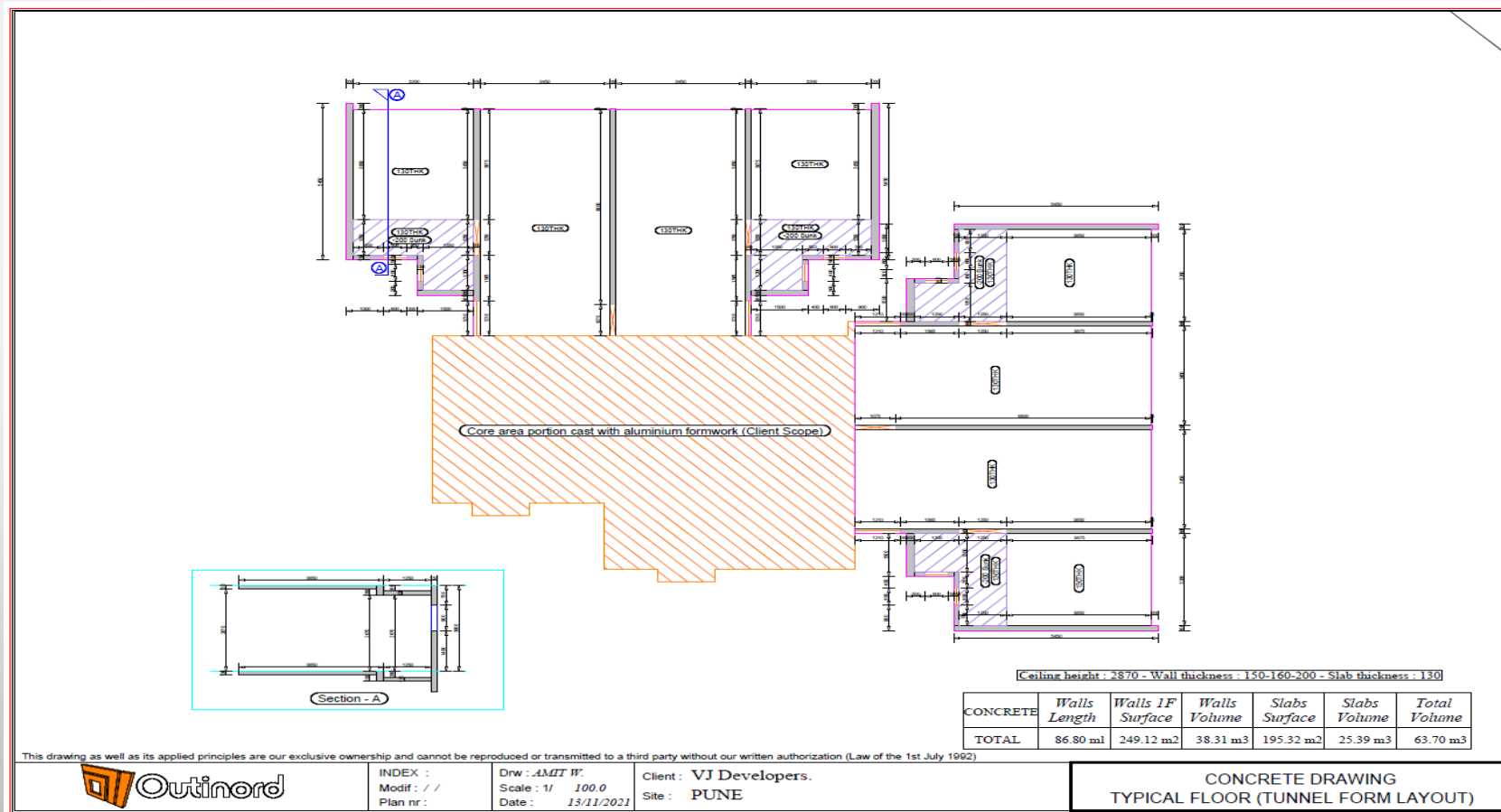



# Vilas Javdekar – EWS Orizzonte 2021

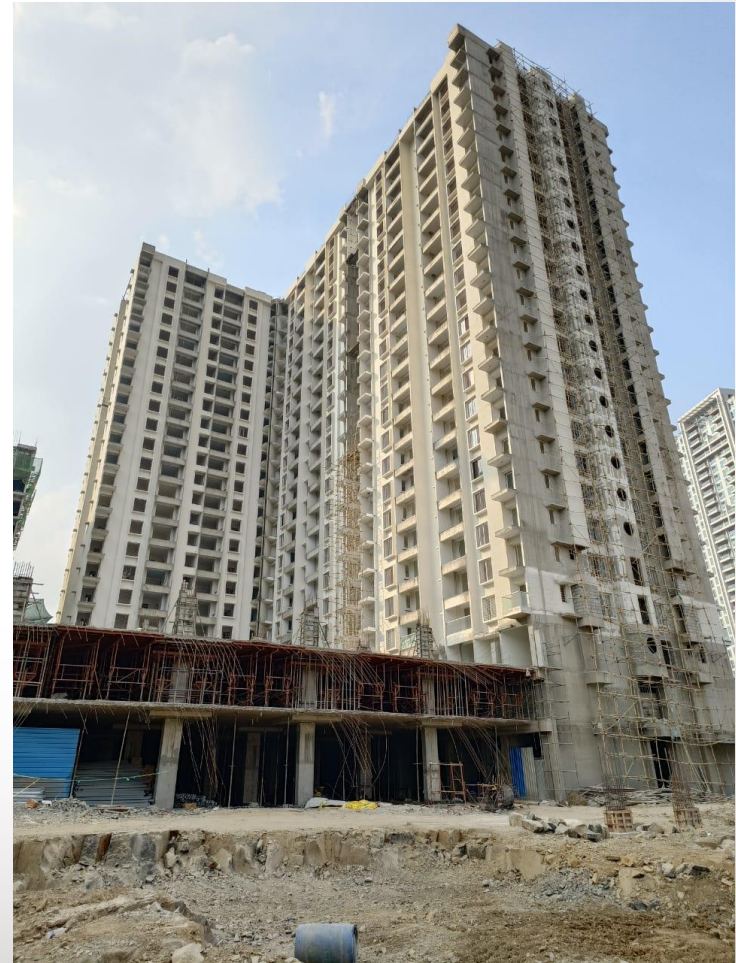

# Vilas Javdekar – Indilife 2022

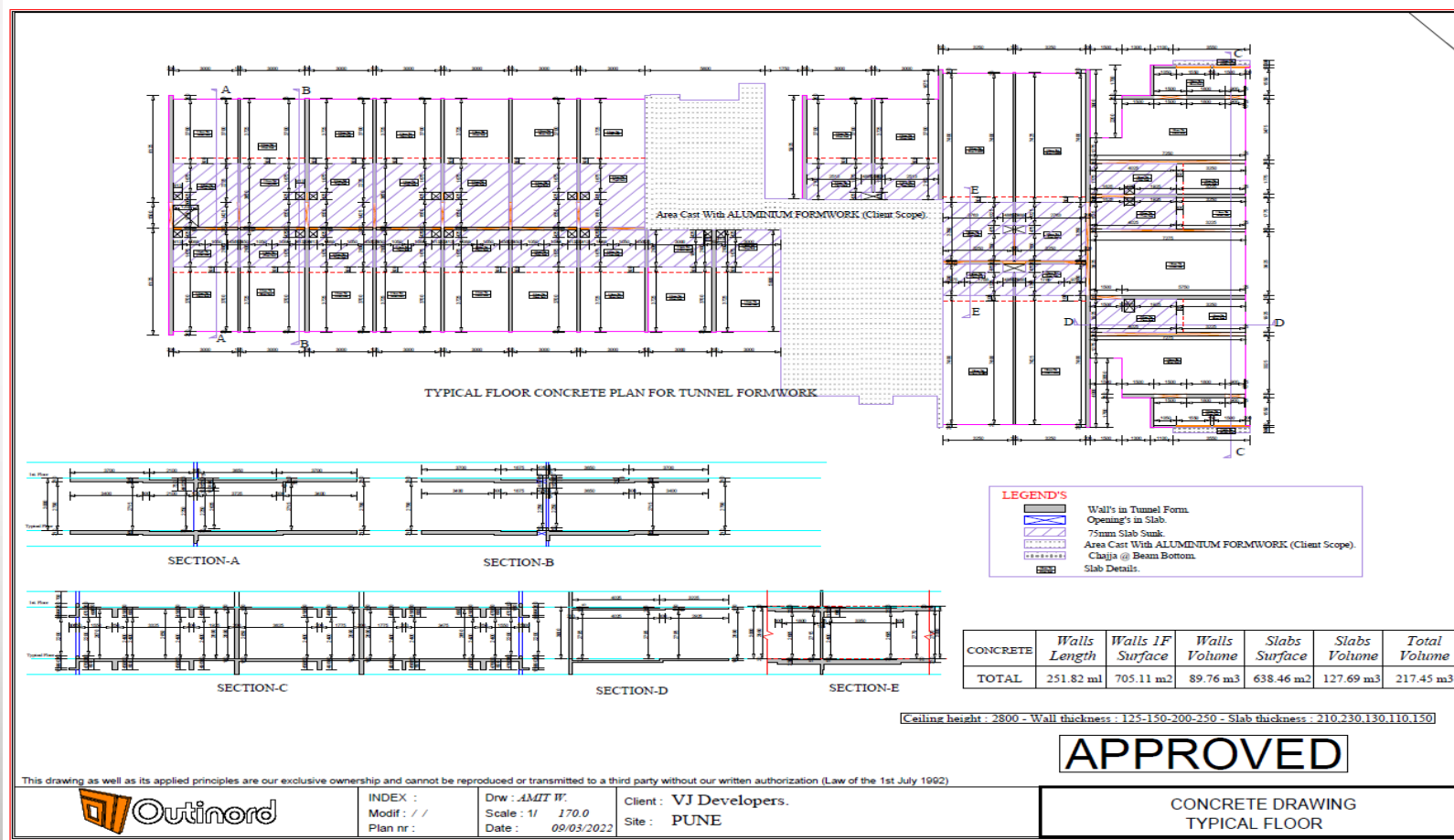



# Vilas Javdekar – Indilife Project 2022





# Shangrila Infracon, Kismatpur project 2022

1<sup>st</sup> time in India we are achieving the milestone of 37 floor.

**abbham**  
AT KISMATPUR

6.4  
ACRES

37  
FLOORS

5  
BLOCKS

366  
UNITS

4  
LEVEL CAR PARKING  
1 CELLAR + 3 PODIUM  
PARKING

Imaginative, creative and way beyond the obvious. Welcome to a life touched by the new light. This is Abbham where imagination stretch to reach beyond to a new age defining lifestyle.

5000 sq.  
6000 sq.  
7000 sq.

Icons: Airplane, Building, Person, Plus

Photograph of the Shangrila Infracon building complex at Kismatpur, showing multiple high-rise towers and a podium level with landscaping.

# Shangrila Infracon, Kismatpur project

REV-02

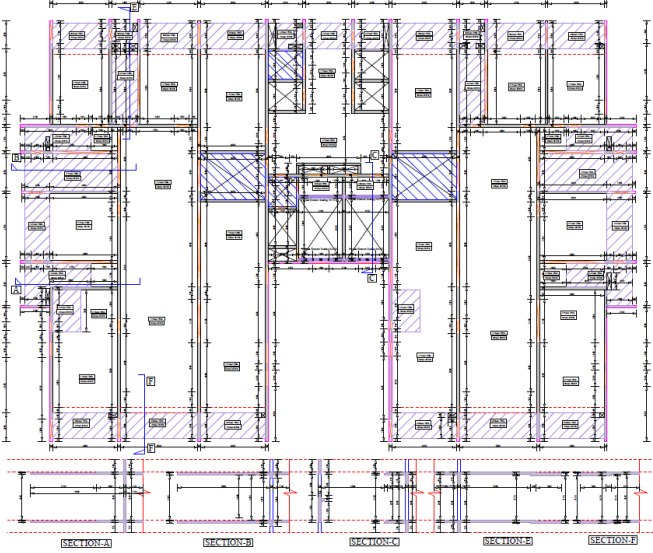

### TOWER A

- LEGENDS:-
- WALL CAST WITH TUNNEL FORMWORK
  - SLAB CAST IN SECONDARY CONSTRUCTION
  - 50mm SLAB SUNK
  - SLAB DETAILS
  - SLAB OPENING'S

APPROVED

This drawing as well as its applied principles are our exclusive ownership and cannot be reproduced or transmitted to a third party without our written authorization (Law of the 1st July 1992)

	INDEX :	Dwg : <i>dwg117</i>	Client : Ms. SHANGRILA INFRACON PVT LTD Site : Kismatpur, Hyderabad
	Modif : 22/09/2022 Plan nr :	Scale : 1/ 170.0 Date : 23/09/2022	

CONCRETE DRAWING  
TYPICAL FLOOR (Tower A)

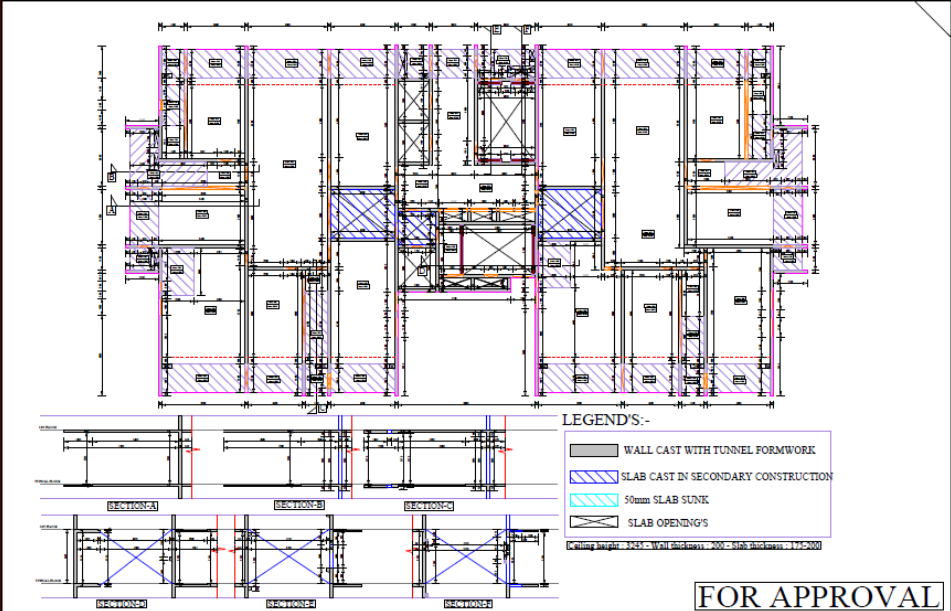

- LEGENDS:-
- WALL CAST WITH TUNNEL FORMWORK
  - SLAB CAST IN SECONDARY CONSTRUCTION
  - 50mm SLAB SUNK
  - SLAB OPENING'S

FOR APPROVAL

This drawing as well as its applied principles are our exclusive ownership and cannot be reproduced or transmitted to a third party without our written authorization (Law of the 1st July 1992)

	INDEX :	Dwg : <i>dwg118</i>	Client : Ms. SHANGRILA INFRACON PVT LTD Site : Kismatpur, Hyderabad
	Modif : 22/09/2022 Plan nr :	Scale : 1/ 150.0 Date : 24/09/2022	

CONCRETE LAYOUT  
BLOCK B&D



Shangrila Infracon, Hyderabad  
No of towers 5 block  
2 set of Tunnel formwork

